



## 250 Industrial Tower

### Double Width Tower Assembly Guide

Product Information and Assembly Guide

## Double Width Tower Assembly Guide

This document will provide all users of Lewis Access Towers with a complete guide to the erection of the Lewis SW (Double Width) Aluminium Tower, employing the 3T (Through the Trap) method.

The user should read the entire contents of this document before commencing assembly and pay particular attention to all of the safety instructions. If the equipment is passed onto another party a copy of these instructions should accompany the handover.

Two persons are necessary to carry out the erection of the equipment detailed in this document. It is strongly recommended that the following items of personal protection equipment be worn at all times: safety boots (EN345 or BS1870 / 4972); safety helmet (EN397 or BS5240); gloves. The SWL (Safe Working Load) for each platform is 275kg, evenly dispersed.

### The Tower is a Class 3 Industrial Tower System

The tower should be manoeuvred into position by hand by pushing it from the base frame. Never attempt to use any mechanical equipment (i.e. a forklift etc.) to move the tower.

If it is necessary to lift individual components whilst assembling the tower, a dependable knot should fasten each item.

Be aware of overhead obstructions – pay particular attention to any live electrical cables. Ensure that no persons, materials or tools are on the tower when it is being moved.

Additional care should be taken when moving the tower on uneven or inclining ground. The use of the castor locks should be deployed when the tower is in position. When moving the tower the stabilisers should only be lifted 35mm from ground level.

**Towers under 4m in height are the only towers that should be moved.**

z Check all components (see component list) are available and in usable condition.  
z Damaged or incorrect components should not be used.

### Working on the Tower - The Beaufort Windscale

**Scale 4, 13 - 18 mph .....OK TO WORK ON TOWER**

**Moderate Breeze:** Raises dust, loose paper; moves small branches

**Scale 5, 19 - 24 mph .....STOP WORKING ON TOWER Scale 6.**

**Fresh Breeze:** Small trees in leaf begin to sway; white crested wavelets form on inland waters

**25 - 31 mph .....DISMANTLE TOWER**

**Strong Breeze:** Large branches in motion; umbrellas used with difficulty; telephone wires "whistle".

Be aware that wind conditions are a very important consideration when using a tower. Attention must be paid to individual situations where wind conditions can increase - i.e. when working between buildings, or close to the corner of a building and at open ends.

Never use tarpaulins or similar covers without seeking the correct advice.

Additional items, such as steps or conventional ladders, must never be used to gain further height from the platform. The tower must be climbed from within the structure, on no occasions should the tower be scaled from the outside. Inspect all the tower components before each use. Pay particular attention to;

- z Castings - check for cracks
- z Welds - free from cracks
- z Tubes/Braces/Rungs - Straight and with indents less than 5mm deep
- z Platforms - no damage, free from debris
- z Castors - moves freely, threads free from damage, brake working
- z Outriggers - straight, feet flat
- z Inspect the equipment for damage regularly, at least daily.

z If damage should occur whilst in use, stop work immediately and isolate the damaged items from the rest of the tower and contact your supplier.

z Check the ground on which the tower is to be used is relatively flat, smooth and capable of supporting the tower.  
z The SWL (Safe Working Load) of the tower is 275kg per platform, inc the weight of the tower - evenly distributed, up to a maximum of 950kgs per tower.

z Do not exceed the SWL.  
z Never attach safety harnesses or similar safety equipment to the tower whilst erecting or dismantling the tower.  
z During assembly, the tower should only be climbed from inside of the frame dimensions, do not scale the tower from the outside.

z Tools and equipment must be loaded onto the platform within the confines of the tower dimensions.  
z Adjustable legs are to be used for levelling.  
z Outriggers should always be deployed when required.

If the area of operation means that the outriggers cannot be deployed in the recommended position – contact Lewis Towers or your supplier for advice.

### Ballast for Towers up to 12.2m in height, ballast is not necessary

## DOUBLE WIDTH INTERNAL AND EXTERNAL USE

Working Height in (m)	3.	3.	4.	4.	5.	5.	5.	6.	7.	7.	8.	8.
Platform Height in (m)	2	7	2	7	2	7	2	7	2	7	2	7
150mm Castor												
Adjustable Leg 500mm												
4 Rung 1m Frames	4	4	4	4	4	4	4	4	4	4	4	4
6 Rung 1.5m Frames	4	4	4	4	4	4	4	4	4	4	4	4
8 Rung 2m Frames	2	2	2	2	4	2	2	4	6	2	2	6
1.8m / 2.5m Fixed Deck	1	2	1	1	1	2	1	1	1	2	1	1
1.8m / 2.5m Trap Deck	1	1	1	1	2	2	2	2	2	4	2	3
1.8 m / 2.5m Horizontal Brace	6	6	6	6	1	1	1	1	1	1	1	1
2.1 m / 2.7m Diagonal Brace	2	2	3	4	0	2	0	0	0	2	0	4
1.8m / 25mm Side Toe Board (Wood)	2	2	2	2	5	10	7	8	9	10	1	1
1.2m End Toe Board (Wood)	2	2	2	2	2	6	2	2	2	10	1	2
Toe Board Clip	4	4	4	4	2	2	2	2	2	2	2	2
Standard Stabilisers	0	0	4	4		2	4	4	4	2	2	2
Jumbo Stabilisers	0	0	0	0		4	4	4	4	4	4	4
Total Self Weight of Tower (Kg) -	92	97	10	12	15	16	17	18	18	20	20	23
1.8m Total Self Weight of Tower (Kg)	10	11	5	8	9	1	4	1	9	1	7	7
- 2.5m	5	0	11	14	17	19	19	20	21	22	23	26
			9	2	9	0	5	3	1	4	0	6

Working Height in (m)	9.	9.	10.2	10.7	11.2	11.7	12.2	12.7	13.2	13.7	14.2
Platform Height in (m)	2	7	8.2	8.7	9.2	9.7	10.2	10.7	11.2	11.7	12.2
150mm Castor			4	4	4	4	4	4	4	4	4
Adjustable Leg 500mm			4	4	4	4	4	4	4	4	4
4 Rung 1m Frames	4	4	2			2	2			2	2
6 Rung 1.5m Frames	4	4		2		2		2		2	
8 Rung 2m Frames	8	2	8	8	1	8	1	1	1	10	1
1.8m / 2.5m Fixed Deck	1	2	1	1	0	1	0	0	2	1	2
1.8m / 2.5m Trap Deck	3	6	3	3	1	3	1	1	1	4	1
1.8 m / 2.5m Horizontal Brace	1	1	1	1	3	14	3	4	4	18	4
2.1 m / 2.7m Diagonal Brace	4	3	4	4	1	18	1	1	1	22	1
1.8m / 25mm Side Toe Board (Wood)	1	14	1	1	4	2	4	4	8	2	8
1.2m End Toe Board (Wood)	3	14	5	6	1	2	1	2	2	2	2
Toe Board Clip	2	2	2	2	7	4	9	0	1	4	3
Standard Stabilisers	2	2	2	2	2	0	2	2		0	2
Jumbo Stabilisers	4	4	4	4	2	4	2	2		4	2
Total Self Weight of Tower (Kg) -	25	26	26	29	29	30	31	34	35	35	36
1.8m Total Self Weight of Tower (Kg)	0	0	4	0	8	8	3	4	1	9	6
- 2.5m	27	29	29	31	33	34	35	38	39	40	41
	9	0	5	7	5	6	1	8	6	4	2

## Double Width Tower Assembly Instructions

### 1.1 Prepare the frame for assembly.

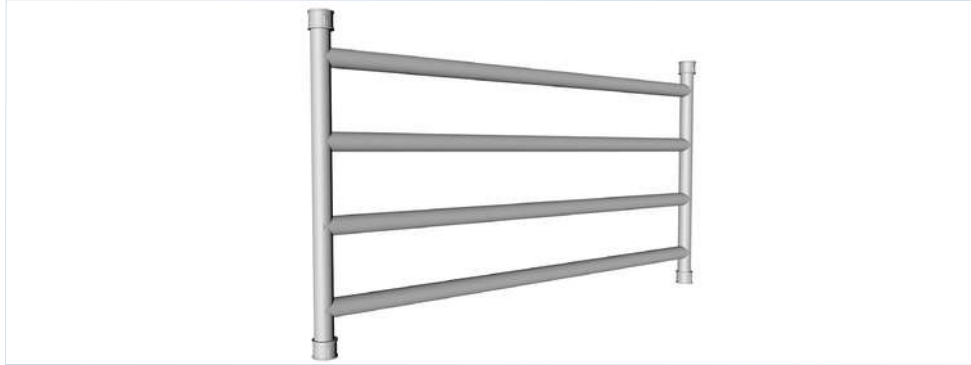

### 1.2 Insert the Adjustable Leg, and then the castor into the bottom of the frame.



### 1.3 Prepare the frame adjacent to the frame in 1.2.

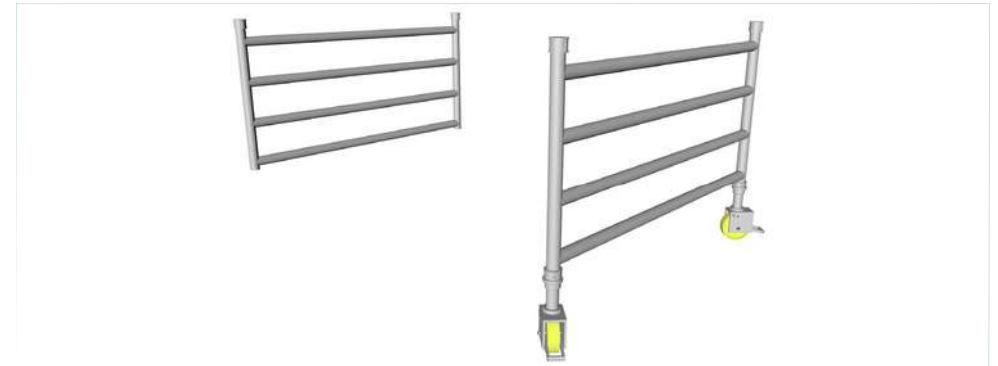

### 1.4 Insert the adjustable leg, then the castor into the bottom of the frame.



### 1.5 Clip the horizontal brace onto the frame. Connect the brace directly above the casting at the first horizontal rung position.

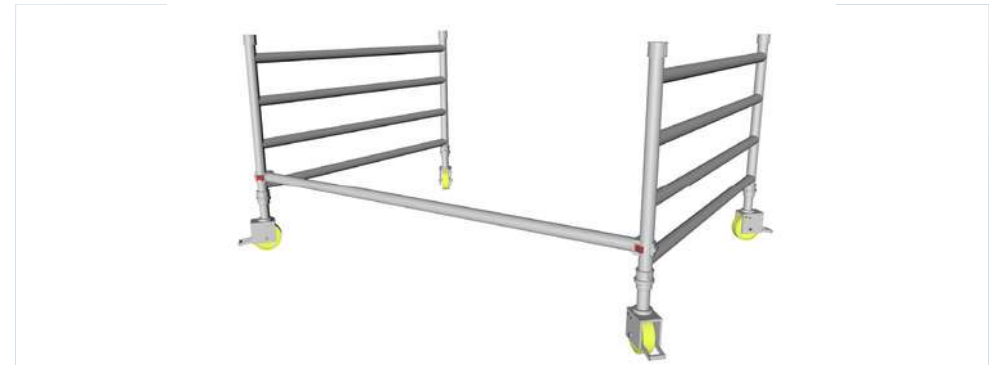

**1.6** Clip the second brace in the same position, on the other side of the frames. Make sure the base is level using a spirit level. Any alterations needed, can be adjusted on the legs.



**1.7** Make sure the Trigger is facing the outside of the frame.

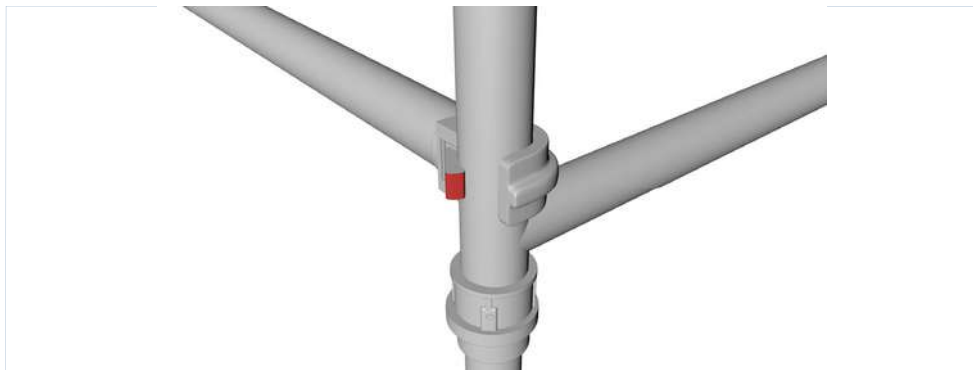

**1.8** Insert the next section – this may vary in size depending on which tower you have. However, the image we have used, is an 8 Rung (2m high) frame.



**1.9** Clip the diagonal braces onto the lowest rungs.



**1.10** Insert the adjacent frame.



**1.11** Clip the diagonal braces onto the lowest rungs.



**1.12** When fitting the stabilisers, position each one in opposing directions, Adjust all four castors to ensure the tower is square and level – You can use a spirit level here to check.



**1.13**

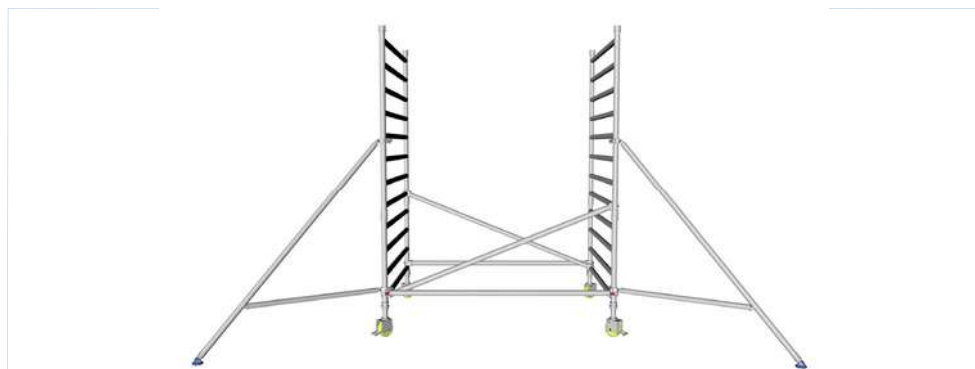

**1.14**



**1.15**

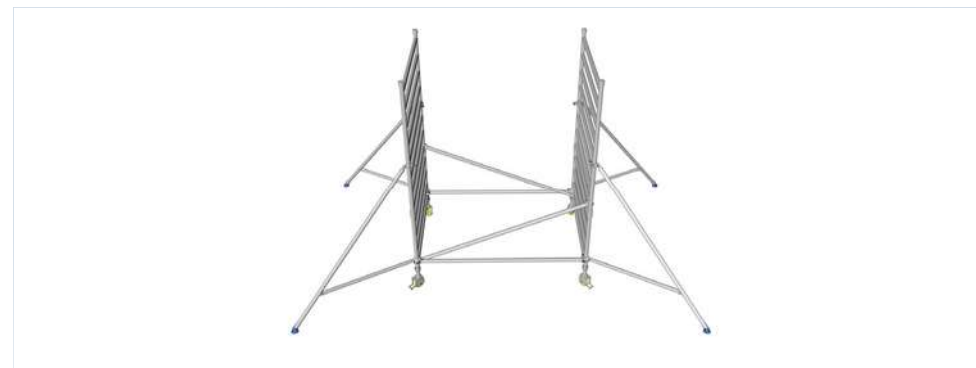

**1.16** Stabilisers must be in opposing directions to ensure full stability of tower.

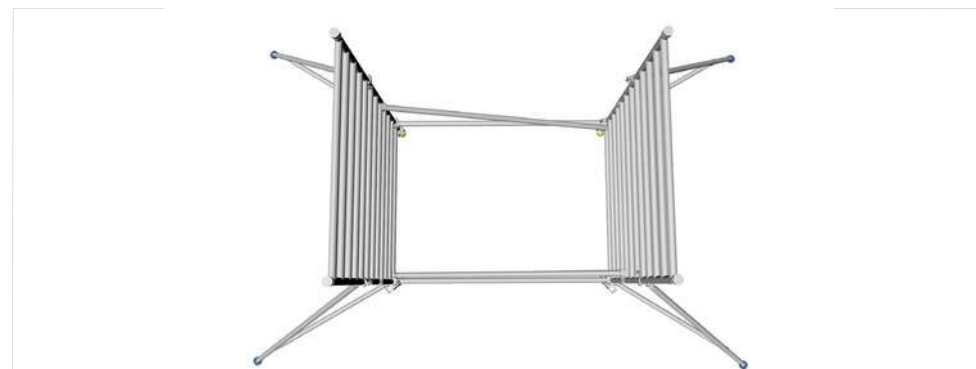

**1.17** Ensure spring clips are located in the locked position.

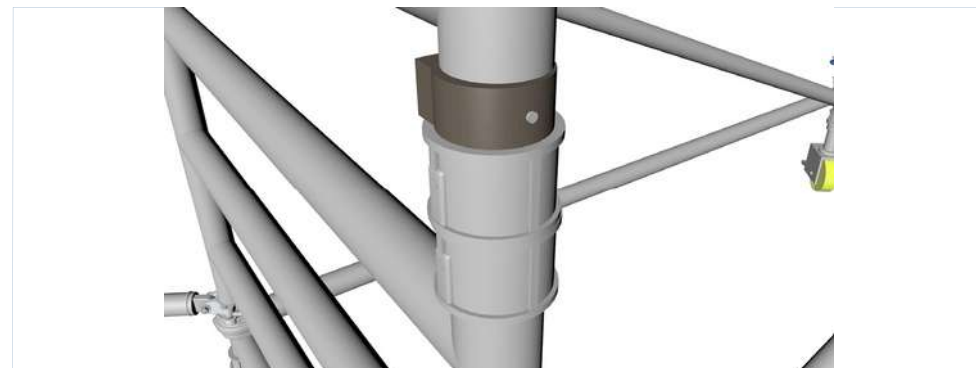

**1.18** Attach the trap door platform approx. 2.2m above ground level. This will be on the 8th Rung, if you started to build the tower with an 8 Rung Section. If you started to build the tower with the 4 Rung (1m) frames, then the 1st platform will be placed approx. 4 Rungs above the frames. This will vary depending on what section you have started to build your tower with.



**1.19** Align the platform alongside the side of the frame.

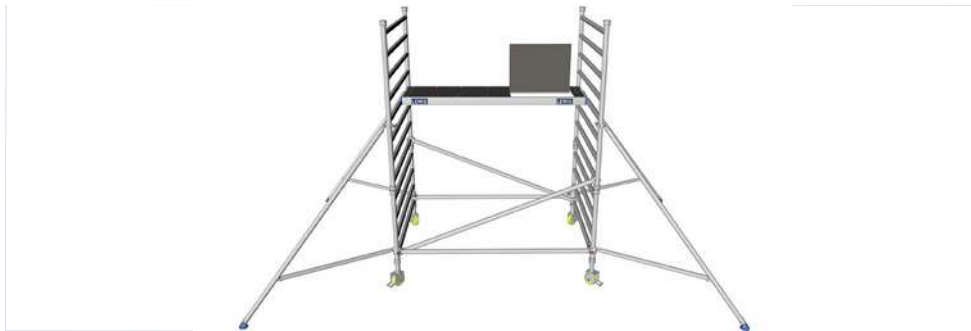

**1.20**

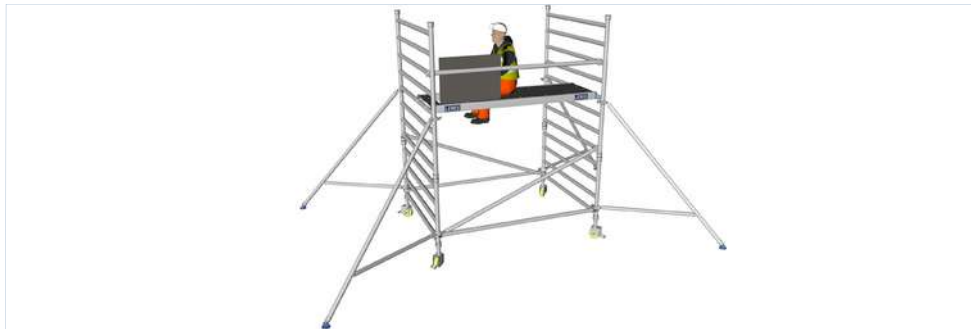

**1.21** Climb internally up the rungs of the frame through the trap door platform. site with feet through the platform, so they are resting on the rung of the frame. Fit four guardrail braces on the 2nd Rung and 4th Rung above the platform. or at approx. 250mm above the platform, then a further 250mm from there.

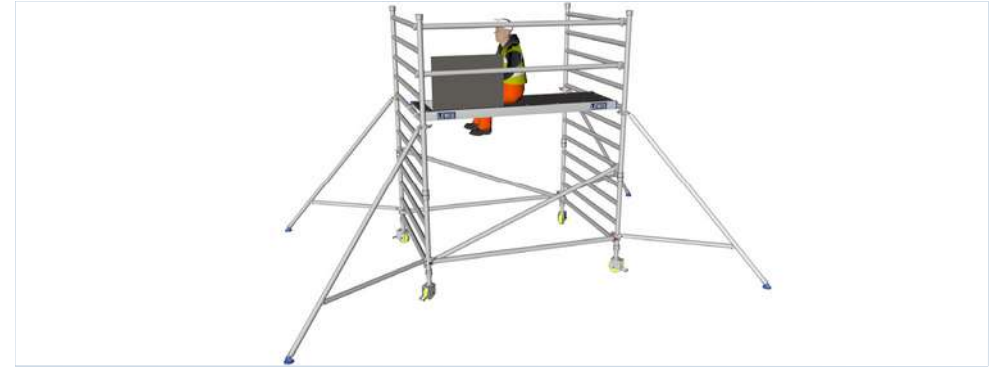

**1.22**



**1.23**



1.24

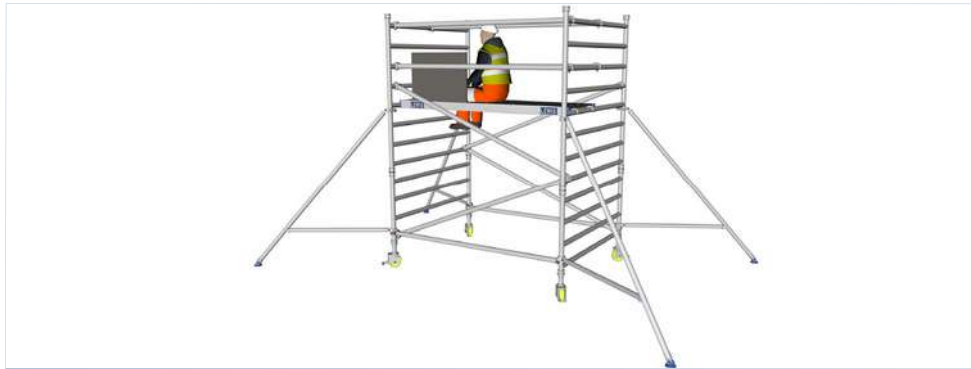

1.25 Clip the diagonal braces into position.



1.26 Stand on the platform and ensure the guardrail are securely in place, at the opposite end of the tower.



1.27 At this point, a platform height of 2.2m has now been built.



1.28 To continue building higher, fit the next set of frames on either side.



1.29 Clip the diagonal braces into place.

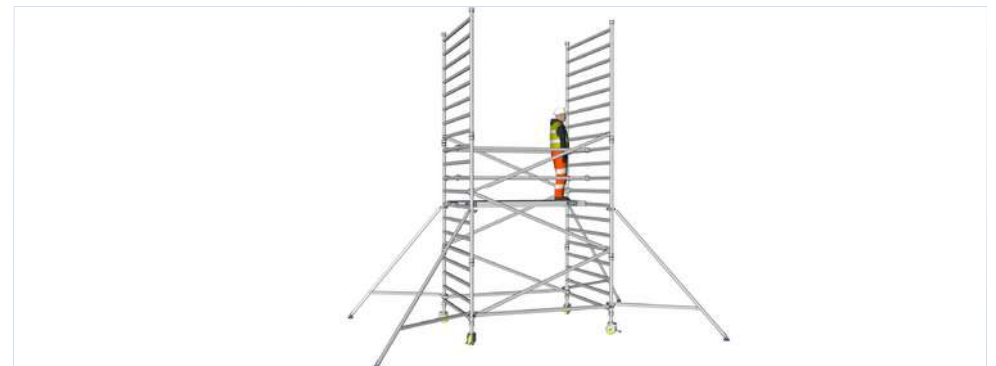

1.30 Ensure the frame clips are securely in place.

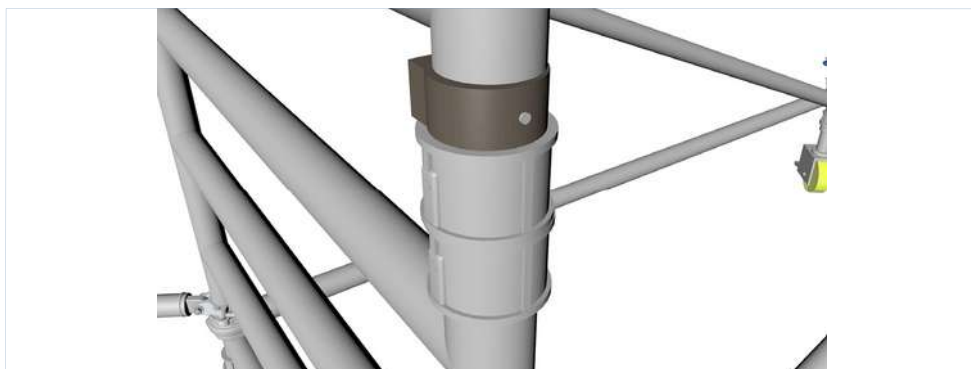

1.31 Insert the platform, once the braces are securely in place. The next platform should be placed approx. 2m above the first. The rungs will vary, depending on the size frames you have, but should be placed around 2m higher.



1.32 Then place the Fixed platform next to the trap door platform, so they are side by side. Ensure there are no gaps between the platforms. They must be pushed together.



1.33 Climb through the trap door, as you did at point 1.21m. stay sitting on the platform, with feet rest on the rung below.



1.34 Place the handrails securely into place whilst sitting.



1.35 Stand on the platform, and ensure all braces are facing the correct way, and are securely in place.





- 1.36 Fit the toeboards securely into place. The Toe board clips to be fitted in all 4 corners of the platform, then place the wood.



- 1.37 The tower has now been built!



### Dismantling

To dismantle the LEWIS Double Width tower, first remove the toeboard set and send safely down the tower. Remove the furthest of the four guardrails and diagonal brace. Go directly to the trappdoor platform next to the ladder frame to remove the braces completely. To fully dismantle the tower reverse the erection procedure detailed in this guide above.

### Stability

Towers left unattended or unused for extended periods in exposed situations should be dismantled. Horizontal forces i.e. pressure exerted when drilling into a building face can yield instability in the tower. The tower must not be used to gain access to a neighbouring structure. Tower are not intended to be suspended.

### Transport and Storage

Components should be transported and stored vertically. Damaged items must be repaired by a competent person. Contact your supplier for advice.



## Further Information

Unit 4 Bellingham Trading Estate

Franthorne Way

London SE6 3BX

T: 0800 043 1234

E: [info@scaffoldtowerhire.co.uk](mailto:info@scaffoldtowerhire.co.uk)

W: [www.scaffoldtowerhire.co.uk](http://www.scaffoldtowerhire.co.uk)